

E 16/2500 and E 22/2550 Concealed Jamb Closers

The concealed jamb closer is integrated into the door for aesthetic and anti-vandal purposes.

Both models can be mounted at any height of the door. Due to its small diameter the E16/2500 model is mainly used in smaller wooden doors, and the E22/2550 with its larger diameter in steel and large wooden doors. The E22/2550 fixing holes coincide with those of the previous model E28.

The spring strength is adjusted by shortening or lengthening the chain as desired, without dismantling the mechanism. The closing force depends amongst others on the used hinges.

The concealed jamb closer can be used in both flush and overlapping doors. It needs no maintenance, but occasional greasing of the moving parts will increase its lifespan.

The exterior parts of the E22/2550 concealed jamb closer, part no. 300319, are made of non-rusting material (aluminium tube, front and counter plate in stainless steel).

A perfect complement make the DICTATOR door dampers.

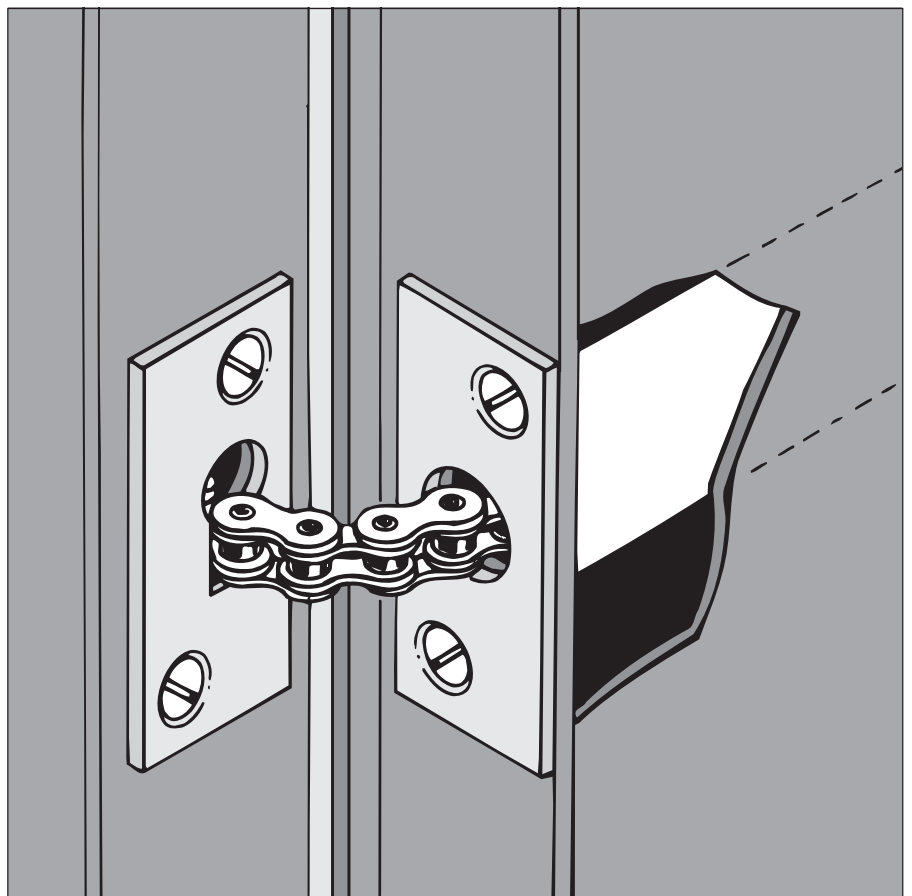

Technical Data

Type	E 16/2500	E 22/2550
Diameter of spring tube	Ø 16 mm	Ø 22 mm
Opening angle of door	up to 180°	up to 180°
Closing performance	from about 150°, depending on the hinges	
Closing force	5 - 15 Nm	15 - 30 Nm
Material of spring tube	aluminium	aluminium
Finish of front and anchor plate	zinc-plated	stainless steel

Mounting

Drill a suitable sized hole in the face side of the door (17 or 23 mm, depending on model) and insert the concealed jamb closer into the hole. If necessary the front plate can be embedded into the door leaf. It is fixed with two countersunk head screws.

Fix the anchor plate exactly opposite and at the same height to the frame. Please make sure there is enough space for the inserted chain links. We recommend to drill a hole of appr. 50 - 80 mm depth and a slightly smaller diameter than the width of the anchor plate. Now connect the chain to the anchor plate on the door frame. Open the door further and remove the securing pin. The concealed jamb closer is now ready for operation.

To adjust the spring force, open the door wide and secure the chain again with the securing pin. To increase the force, shorten the chain.

Please note that tensioning the closing spring on the concealed jamb closers too much and/or outside placed hinges could reduce the opening angle of the door. Continuing to open the door to 180° could damage both the concealed jamb closer and the door.

Dimensions

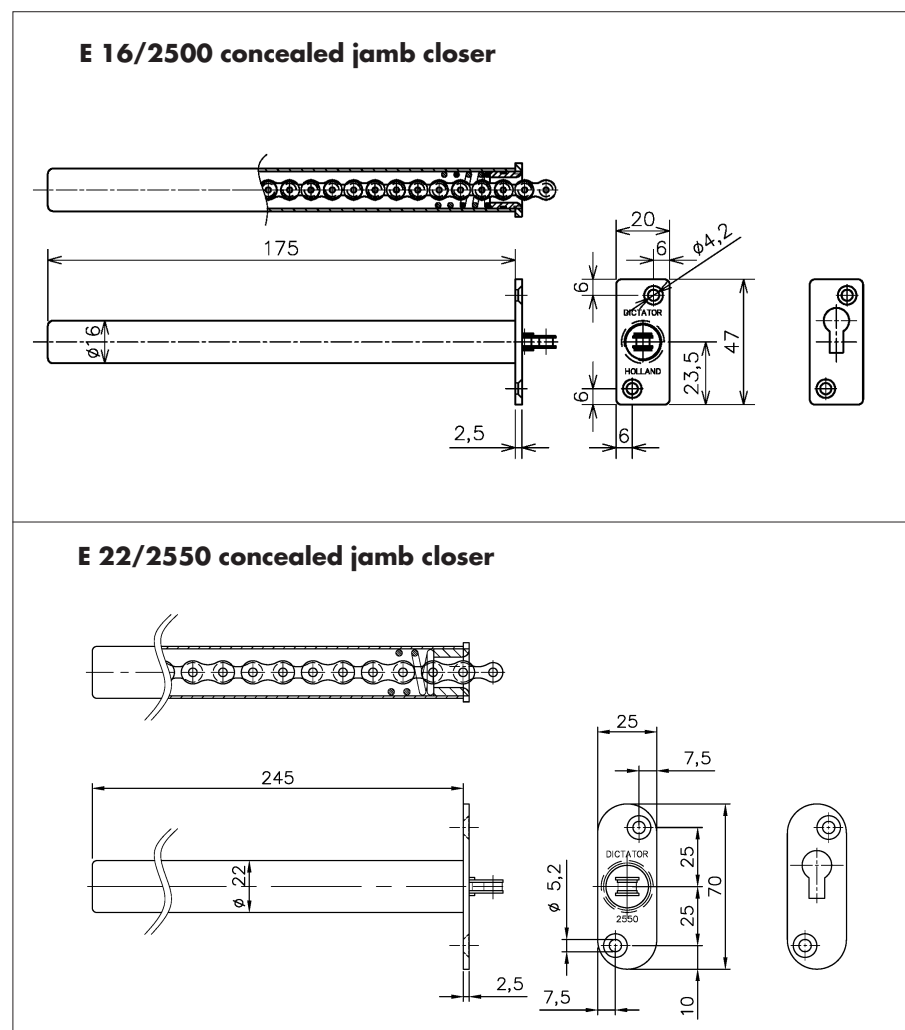

Order Information

Concealed jamb closer E 16/2500

part no. 300371

Concealed jamb closer E 22/2550

part no. 300319