

DICTATOR RTS Tube Door Closer

The "Invisible" Door Closer

The DICTATOR RTS tube door closer is virtually invisible because being built into the door. The joint can only be seen when the door is open.

The DICTATOR RTS tube door closer is often used on **outside gates** such as garden entrance gates, admission gates into industrial plants and admission control gates. These gates usually do not have a frame above the door where the operating lever of a normal overhead door closer could be fitted. Furthermore the **concealed fitting** protects the door closer from atmospheric conditions and against **vandalism**.

The tube door closer is particularly suitable for aluminium and steel doors/gates. It can also be fitted into the profile of an existing door. For wooden doors with minimum 40 mm thickness, a tube door closer with special fitting plates can be supplied.

Due to its flexible abrasion-proof plastic joint, the tube door closer can be used with different hinges. However the dimensions described on page 02.029.00 must be observed. Depending on the hinges, the doors/gates can be **opened to 180°**.



Technical Data

Material	steel
Door opening angle	90° - 180°, depending on hinges
Door weight	up to ca. 80 kg
Door height	up to ca. 2500 mm
Width of door leaf	ca. 750 mm to 1150 mm
Types of doors	steel, aluminium and wood
Closing speed	adjustable

Operation

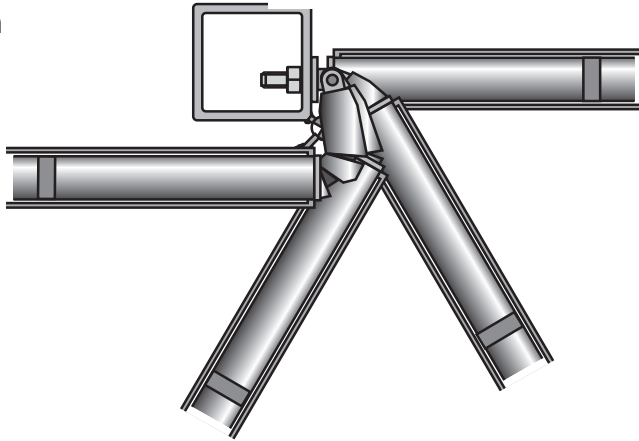

The RTS tube door closer is inserted into the door and connected to the counter-plate (which is fixed to the frame) by an elastic joint with integrated steel ropes. When the door is opened the joint is pulled out and the closing spring inside the RTS is tensioned. The closing speed is controlled by the hydraulic damping cylinder in the middle of the tube door closer. It is adjustable and can therefore be adapted to suit different requirements.

Installation Instructions

Fit the RTS tube door closer into the door, near one of the hinges if possible. With aluminium and steel doors it is usually fitted into the profile of the door. When fitting to wooden doors already existing, we recommend you mill a recess into the door (in the top or the bottom) into which the door closer can be placed. However it is possible to fit the tube door closer anywhere in the wooden door. Fix the front plate of the door closer to the door (with wooden doors sink the front plate into the door. With steel or aluminium doors it may be necessary to provide reinforcement plates with threaded inserts). Make sure the long groove in the joint never points to the side of the door hinges (access to the adjusting screw).

Now fix the counter plate to the door frame at the same height and position as the front plate. Screw the self-locking eyelet with thread into the counter plate. The asymmetric eyelet balances out smaller differences in height between door closer and counter plate. The latch action can be adjusted by screwing the eyelet into the counter plate (latch action: eyelet enters about 15 to 17 mm into the front tube of the RTS - measured from the centre of the hole of the eyelet). **IMPORTANT:** The thread of the eyelet has a special self-locking coating which prevents the eyelet from turning any further 30 minutes after the eyelet has been screwed into the counter plate.

Now connect the bronze alloy fork to the eyelet with a bolt and secure it with the snap ring. We recommend you lubricate the bolt slightly as this prolongs its life considerably. Open the door completely and remove the securing pin from the joint. The door closer is now ready for operation. Should you ever need to remove the door closer or disconnect it from the counter plate, insert the securing pin back into the joint first!

Adjusting the Closing Speed

To adjust the closing speed open the door between 45° and 90° and push the long arm of the hexagon socket screw key into the inclined boring of the plastic joint until the key clicks into place. One turn clockwise will increase the damping (slower closing speed) and turning anti-clockwise will reduce the damping (faster closing).

The closing speed should be checked after each half turn of the key (180°).

IMPORTANT: When the slowest closing speed has been reached (door almost stops), do not continue turning the adjusting key clockwise as this will damage the door closer.

Handling Instruction:

Never push the door closed! There is the risk that the joint buckles and gets damaged.

Installing the RTS Tube Door Closer Important Hinge Dimensions

Installing in Aluminium and Steel Doors

Warning:

Dimensions W, X and Y must be observed! Otherwise the opening angle, latch action and closing will be affected.

If you have any queries, please contact our Advisory Service.

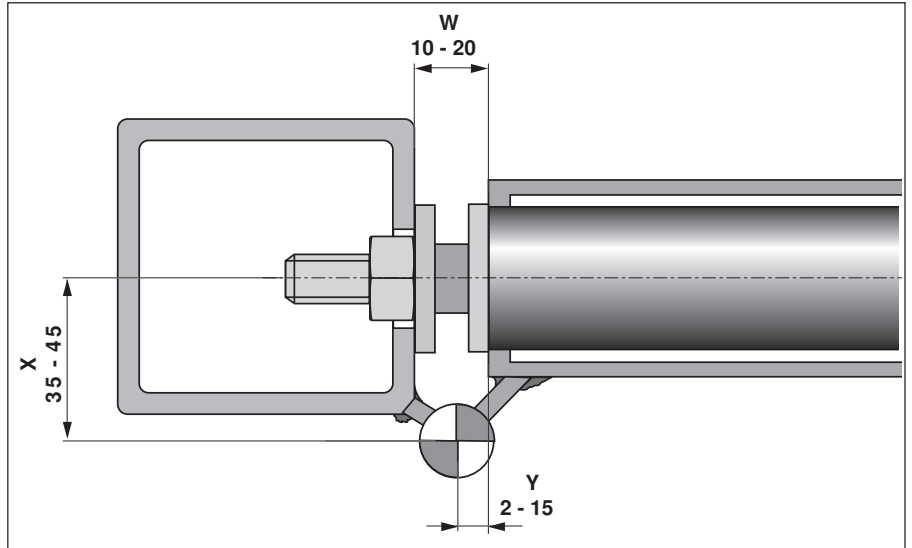

Fitting to Flush Wooden Doors

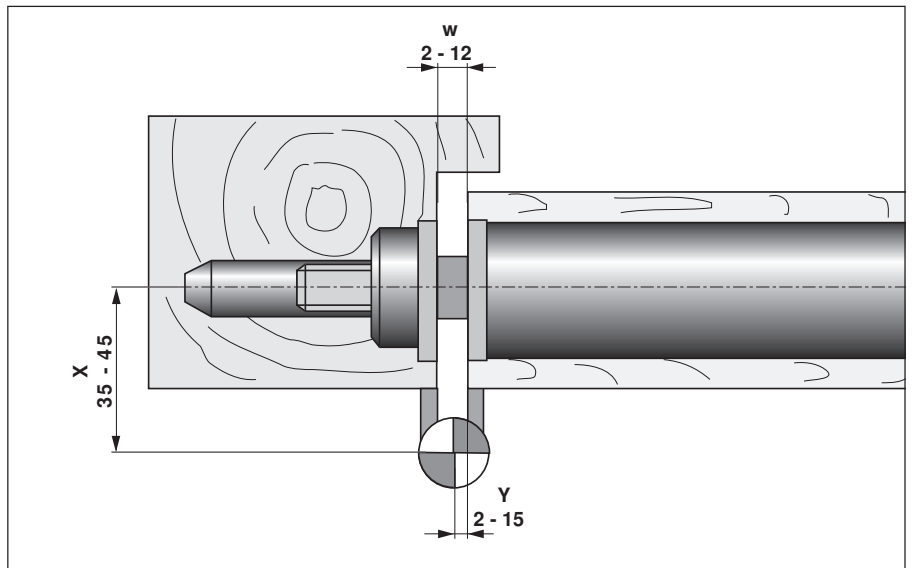

Fitting to Access Doors and Gates in Fences with Screw-Hinges (WARNING: Use Angled Eyelet!)

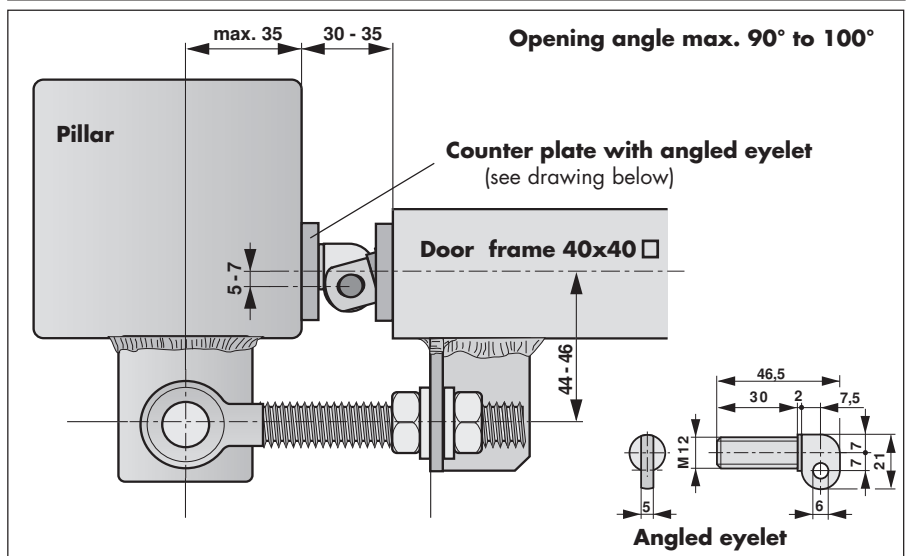



RTS - d and RTS - e Tube Door Closers

DICTATOR RTS - d and RTS - e tube door closers are designed for steel and aluminium doors. Their front plate is fixed to the door with two M8-screws. The RTS - d and RTS - e only differ in the position of the holes on the front plate. Due to its fixing holes the RTS - e can be used in place of the GEZE ROR TS 450 tube door closer .

With aluminium doors the door closer is usually fitted into the bottom profile of the door; in steel doors it is either fitted into the top or bottom profile.

In case it is not possible to install the door closer RTS - e into the door there is a casing available to mount this RTS onto the door. For further information see page 02.032.01.

Technical Data

Model	400520	400529*
Length (dimension B)	734 mm	734 mm
Opening angle	180° (max.)	180° (max.)
Width of door leaf	750 - 1150 mm	750 - 1150 mm
Height of door leaf	up to 2500 mm	up to 2500 mm
Weight of door leaf	up to 80 kg	up to 80 kg
Dimension X of hinges	35 - 45 mm	35 - 45 mm
Opening direction	both DIN right and DIN left	

* Front plates correspond to those of the GEZE ROR TS 450

Dimensions

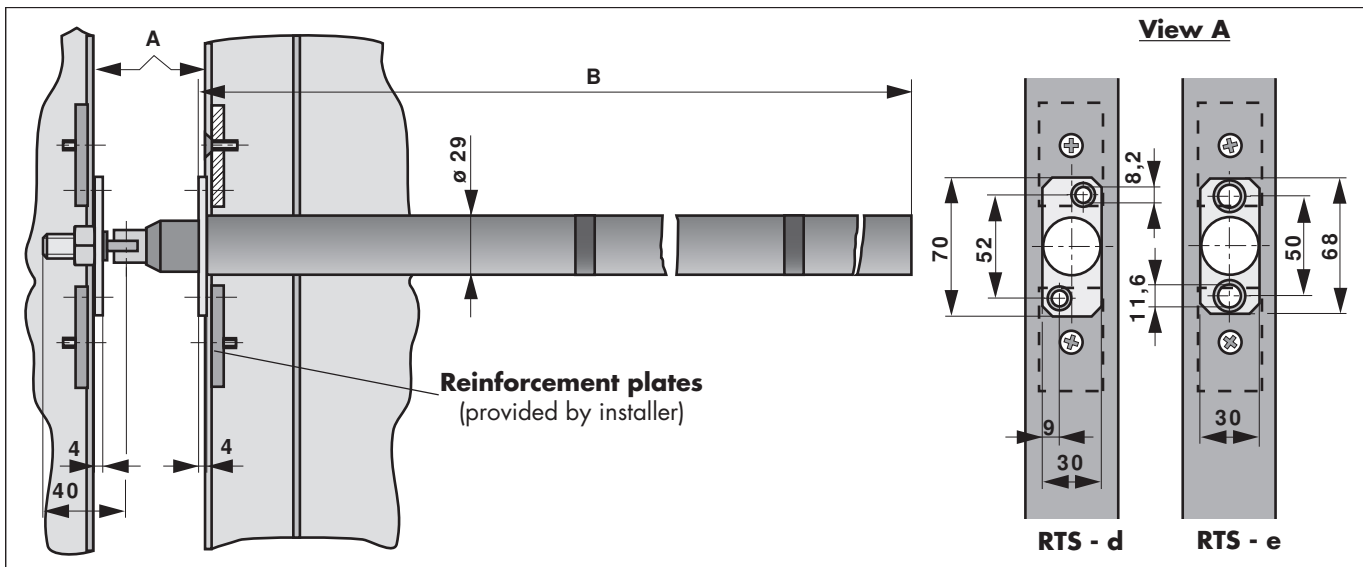

Order Information

RTS - d tube door closer	part no. 400520
RTS - e tube door closer	part no. 400529

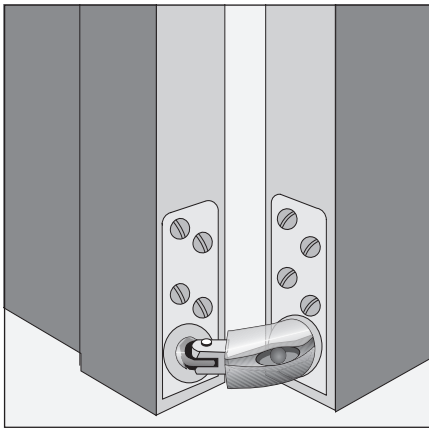

RTS - t and RTS - u Tube Door Closers

DICTATOR RTS - t and RTS - u tube door closers are equipped with a single-sided front plate. They are designed for fixing to either the top or bottom of the door.

In steel doors the thread for the fixing screws can usually be cut directly into the door. Should this not be possible, threaded inserts need to be riveted to the door. With aluminium doors, reinforcement plates should be inserted.

RTS - t and RTS - u tube door closers only differ in the position of their adjustment groove in the joint. It is therefore important when choosing RTS - t or RTS - u tube door closers to observe the fitting position (at the top or bottom) and the DIN-opening direction of the door.

Technical Data

Models

400525

400526

Length (dimension B)	734 mm	734 mm
Opening angle	180° (max.)	180° (max.)
Width of door leaf	up to 1150 mm	
Height of door leaf	up to 2500 mm	
Weight of door leaf	up to 80 kg	
Opening direction		
Fitted at the top	DIN left	DIN right
Fitted at the bottom	DIN right	DIN left

ATTENTION:

With wooden doors the door closer can only be fitted to flush doors!

Dimensions

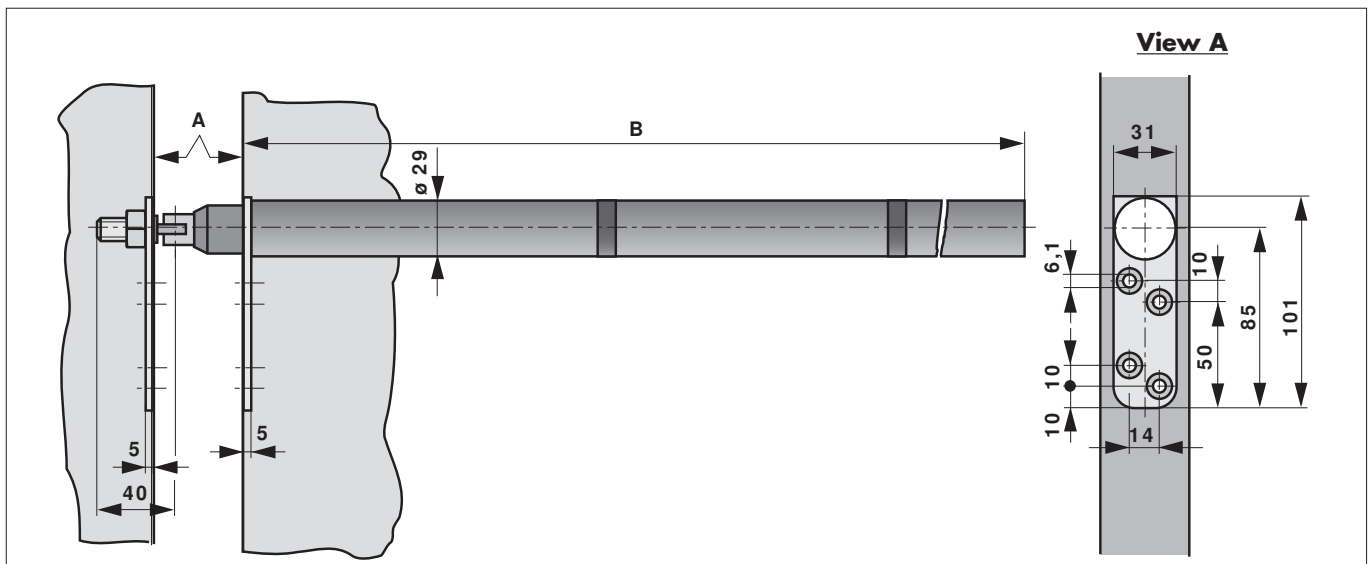

Order Information

RTS - t tube door closer

part no. 400525

RTS - u tube door closer

part no. 400526

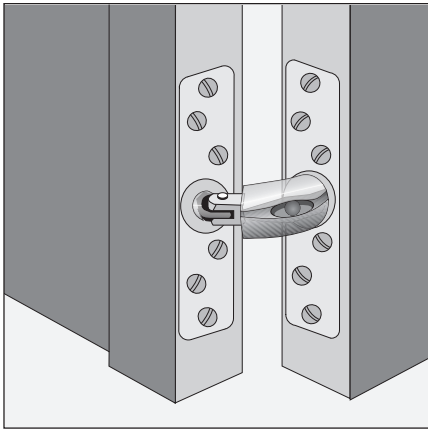

RTS - v Tube Door Closer

DICTATOR RTS - v tube door closers are specifically designed for flush wooden doors, which are fitted with the tube door closer during manufacture.

Although the tube door closer can be fitted in any position, we recommend you fit it at the centre point between the hinges. This will reduce stress on the hinges and door.

Technical Data

Model	400527
Length (dimension B)	734 mm
Opening angle	180° (max.)
Width of door leaf	up to 1150 mm
Height of door leaf	up to 2500 mm
Weight of door leaf	up to 80 kg
Opening direction	DIN left and right

ATTENTION:

The RTS - v tube door closer can only be used on flush doors!

Dimensions

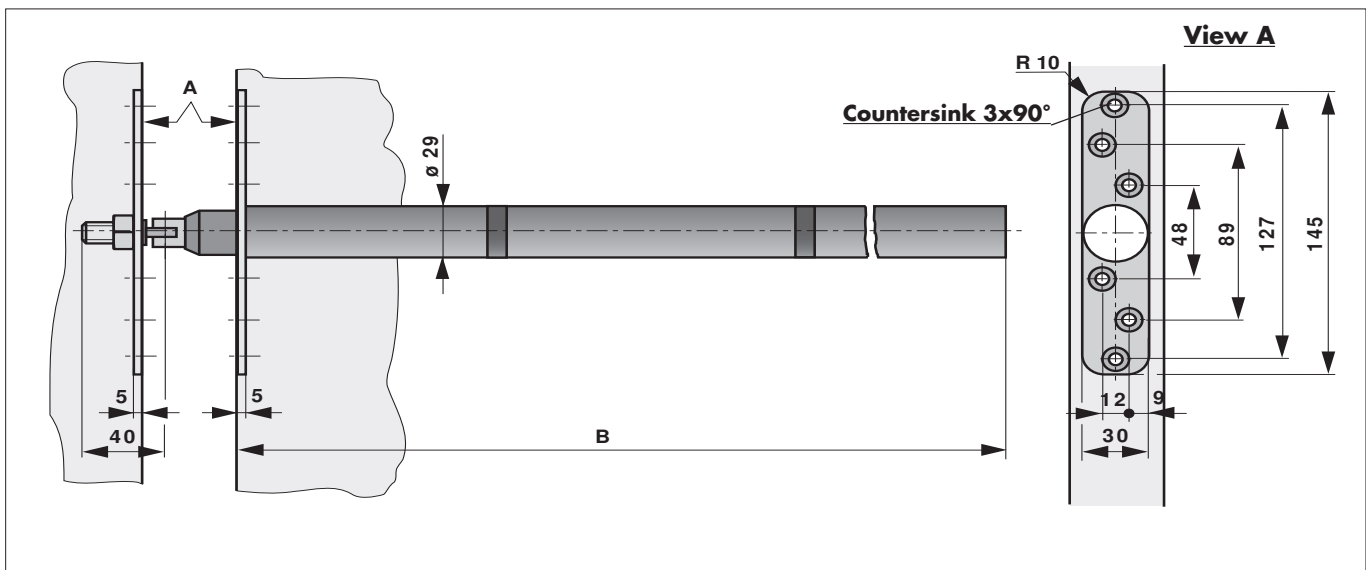

Order Information

RTS - v tube door closer

part no. 400527



Casing for Surface Installation of the RTS - e

This casing has been developed to allow the installation of the door closer RTS - e, part no. 400529, also on doors with flush hinges or without tube frame profile. It also facilitates retrofitting. As long as the measurements shown below are observed, this casing permits to mount the RTS - e on all kinds of doors. With steel doors the casing can be welded onto the door already in production. The same applies to the mounting plate on the jamb.

Very important is that you observe the measurements given below. Depending on the alignment of the hinges the doors can be opened up to 180°. By default the casing is zinc-plated. On demand, larger quantities can also be furnished with powder coat.

Important Hinge Dimensions

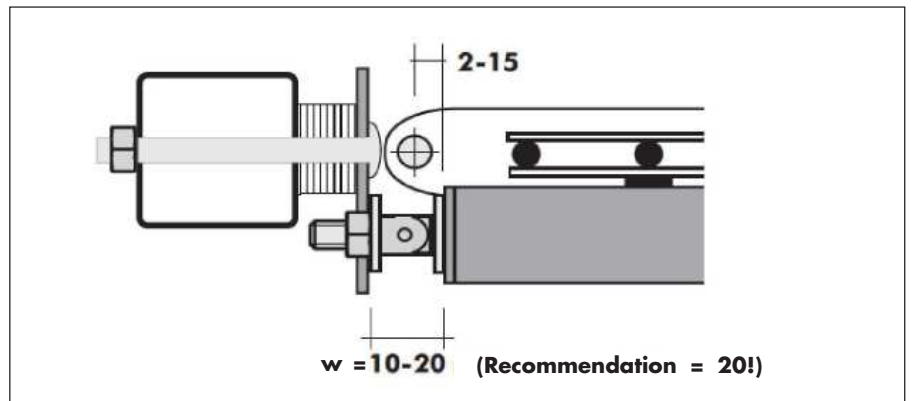

Dimensions Casing

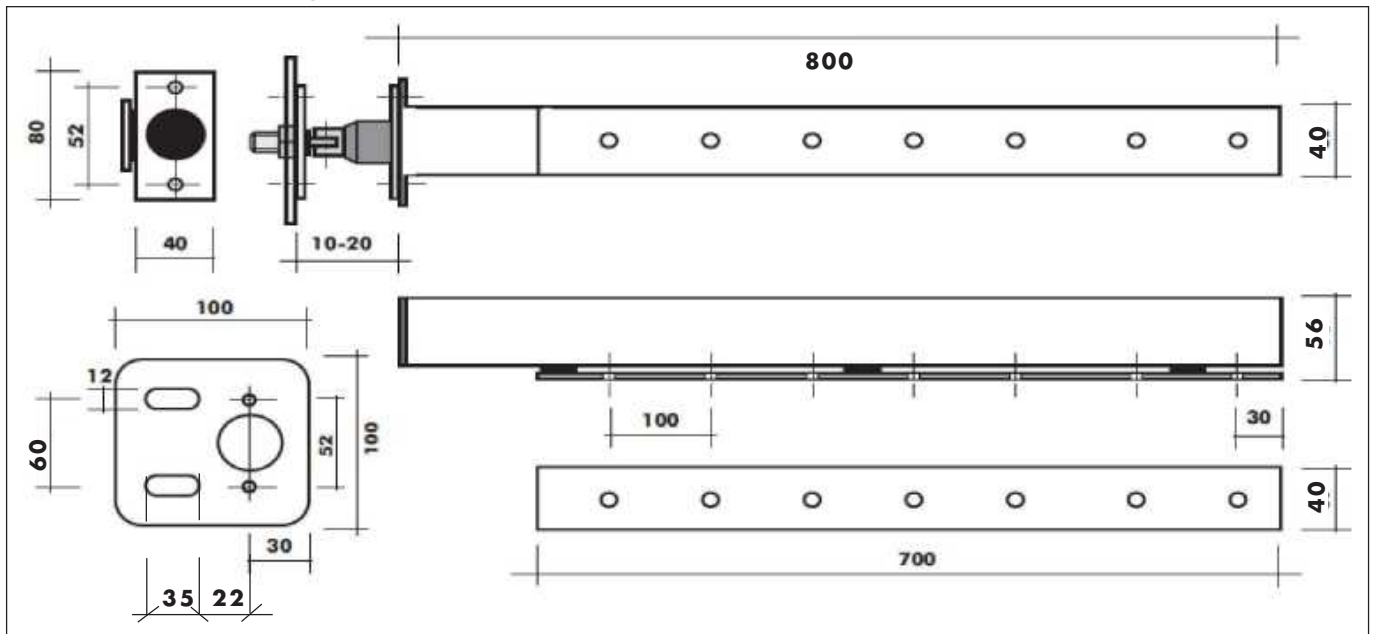

Components Included

Casing for surface installation

Fixing plate with screws

Mounting plate for the jamb with screws and washers

Order Information

Casing for surface installation of RTS - e (400529)

part no. 400594

