

## **DICTATOR Final Dampers**

### **For Fire Protection Sliding Doors**

DICTATOR final dampers provide reliable final damping for fire protection sliding doors.

The DICTATOR dampers have officially been tested for the use on fire protection sliding doors and they are subject to an independent quality control by the MPA-NRW.

The force of the damping can be varied continuously by turning the extended piston rod. Thus the dampers can be adjusted to match the requirements of different doors. The comparatively long stroke ensures high safety as the door moves into the final position at a very slow speed.

Most dampers have an integrated spring which returns the piston rod to the extended position. We recommend the EDHM model for lightweight doors as it has a zero return force. A permanent magnet fixed to the piston rod pulls the rod out again as soon as the door moves away from the damper.

Besides the dampers with one piston rod we also produce a model with a piston rod on both sides.



### **Technical Data**

Diameter of piston rod	10, 12 mm
Diameter of cylinder	28, 35 mm
Material piston rod	steel, hard chromed
Material cylinder	steel tube, zinc-plated
Strokes	50, 75, 90, 100, 200 mm
Damping forces	till 4400 N
Operating temperature	0 °C to +50 °C

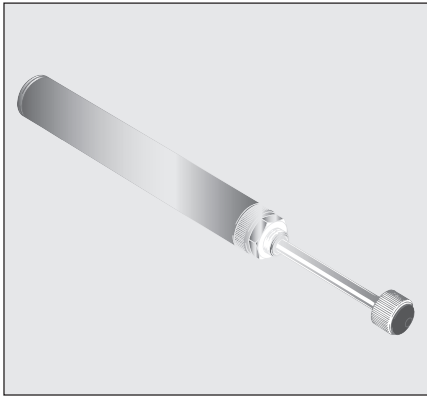

### EDH 28 Final Damper with Single Thread

Fix the damper with its nut and thread. Please make sure the impact direction is exactly parallel to the axis of the damper. A special fixing block is available as an extra accessory.

The damper is adjusted by turning the extended piston rod. The door should be slowed down gently, making sure it closes completely.

For heavier doors we recommend the EDH 35 damper with threads on both ends of the cylinder.

### Dimensions

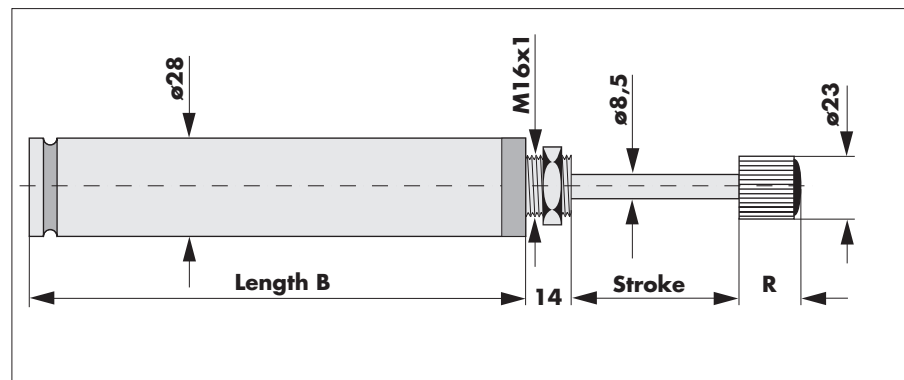

### Technical Data and Order Information

#### EDH 28 with single thread

Part no.	Stroke [mm]	Door weight max. [kg]	Impact mass max. [N]	Returning force max. [N]	Length B [mm]	Buffer R [mm]
200206	100	3000	3100	30	257	25
200209	75	3000	3100	30	185	25

**Advice:** In the chapter Damping Engineering of our DICTATOR catalogue you will find dampers with needle adjustment. The damping of these can be adjusted by a screw located in the piston rod.

### Accessories

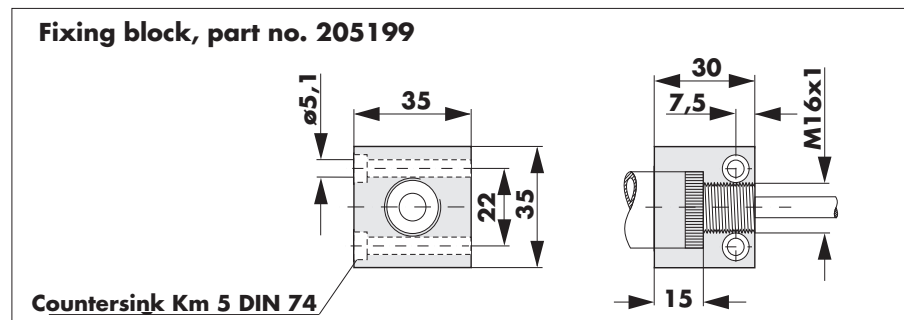
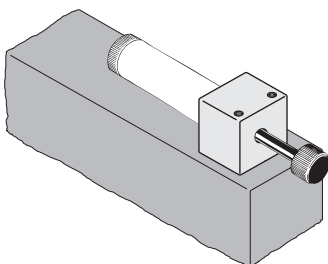

Fixing block

Part no. 205199

Fixing angle (see next page)

Part no. 700159

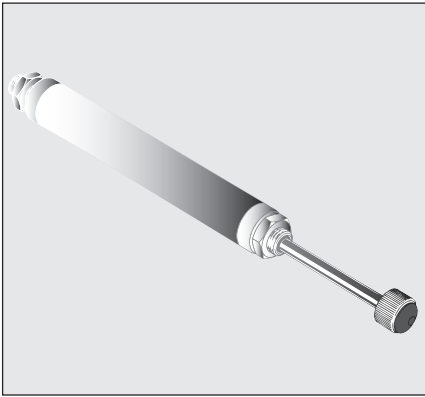

### EDH 28 Final Damper with Thread on Both Ends of the Cylinder

The damper is fixed with both the nuts and threads. Please make sure the impact direction is exactly parallel to the axis of the damper. The additional thread at the end of the cylinder ensures a secure fixing even for heavier doors.

The damper is adjusted by turning the extended piston rod. The door should be slowed down gently, making sure it closes completely.

### Dimensions

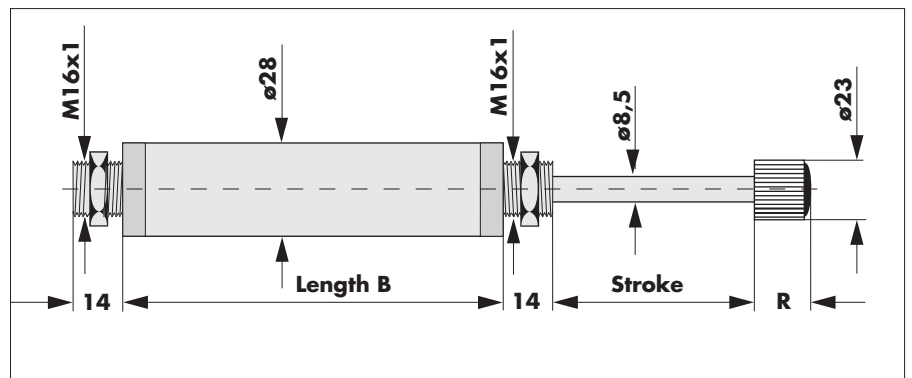

### Technical Data and Order Information

#### EDH 28 with threads on both ends of the cylinder

Part no.	Stroke [mm]	Door weight max. [kg]	Impact mass max. [N]	Returning force max. [N]	Length B [mm]	Buffer R [mm]
200207	90	3000	3100	30	220	25

**Advice:** In the chapter Damping Engineering of our DICTATOR catalogue you will find dampers with needle adjustment. The damping of these can be adjusted by a screw located in the piston rod.

### Accessories

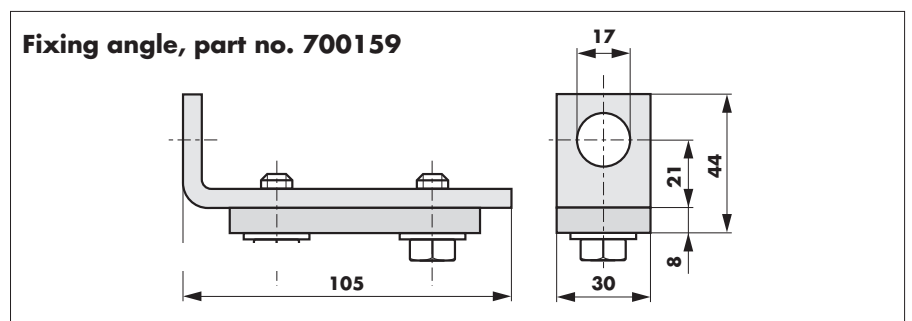
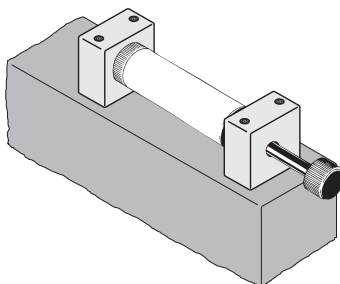

Fixing block (see last page)

Part no. 205199

Fixing angle

Part no. 700159

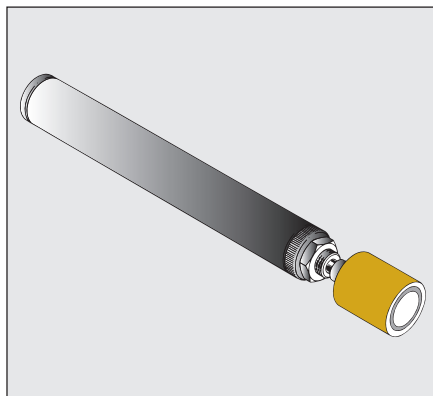

## EDHM 28 Final Damper with Magnet

The EDH 28 final damper with magnet is particularly recommended for lightweight sliding doors as it has a zero return force. When the door opens the magnet pulls the piston rod back to the extended position.

The damping force is adjusted by turning the extended piston rod. The door should be slowed down gently, making sure it closes completely.

As a counterpart of the magnet, please provide a flat iron or use our AP GD 50 G 16 counter plate (part no. 040025, see chapter Fire Door Control Solutions, page 07.041.00) when installing the damper.

The damper is fixed with the nut and thread. Please make sure the impact direction is exactly parallel to the axis of the damper. Please use the EDHM damper with two threads on heavier doors.

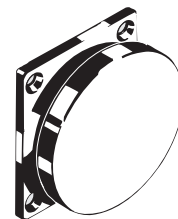

Fixing blocks are available as extra accessories (please see diagrams on preceding pages).

## Dimensions

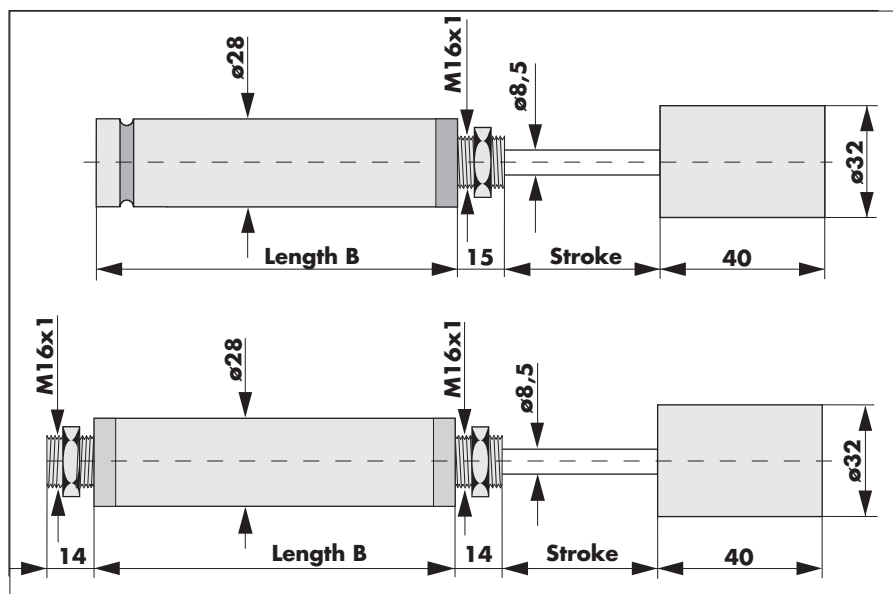

## Technical Data and Order Information

### EDHM 28 with one thread and magnet

Part no.	Stroke [mm]	Door weight max. [kg]	Impact mass max. [N]	Returning force max. [N]	Length B [mm]	Magnet
203150	50	3000	5200	0	130	ø 32

### EDHM 28 with threads on both ends of the cylinder and with magnet

203015	120	3000	2600	0	220	ø 32
--------	-----	------	------	---	-----	------

**Advice:** To help you select the appropriate damper, formulae and examples for calculating the required damping force can be found in the chapter Damping Engineering.

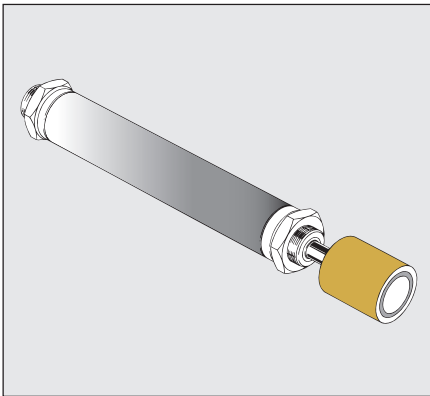

### EDH 35 Final Damper with Magnet or Returning Mechanism

The EDH 35 final damper with magnet or integrated returning mechanism is designed especially for sliding doors. The type EDHM with magnet disposes of no integrated return spring thus ensuring also smoothly running lightweight sliding doors to stay completely closed. When opening the door the magnet pulls the piston rod back to the extended position.

When installing the damper please provide as a counterpart of the damper a flat iron or use our AP GD 50 G 16 counter plate (part no. 040025, see chapter Fire Door Control Solutions, page 07.041.00).

The damper is fixed with the nut and thread. Please make sure the impact direction is exactly parallel to the axis of the damper, otherwise it can become damaged.

### Dimensions

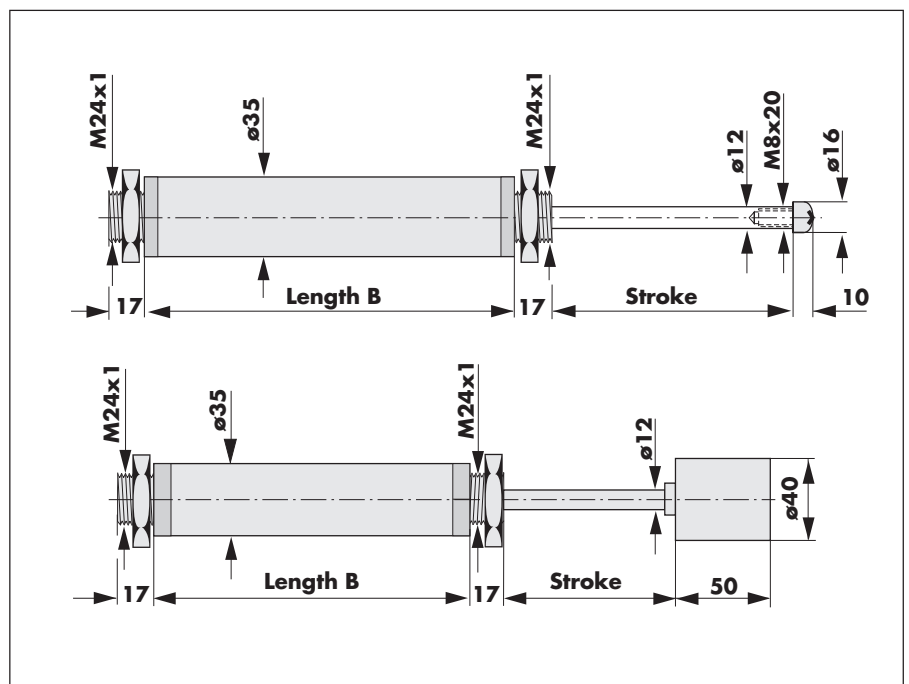

### Technical Data and Order Information

#### EDH 35 with threads on both ends of the cylinder

Part no.	Stroke [mm]	Door weight max. [kg]	Impact mass max. [N]	Returning force max. [N]	Length B [mm]	Magnet
203115*	200	6000	4400	30	330	-

\* Damper had the expired German certificate no.130119826. It is replaced by the EDHM35, part no. 200600.

#### EDH 35 with threads on both ends of the cylinder and with magnet

200600**	200	6000	4400	0	330	ø 40
----------	-----	------	------	---	-----	------

\*\* Number of German surveillance contract: Do 11.3

### Accessories

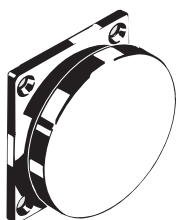

Counter plate AP GD 50 G 16

Part no. 040025

Buffers to screw on (only for type 203115)

see chapter Damping Engineering

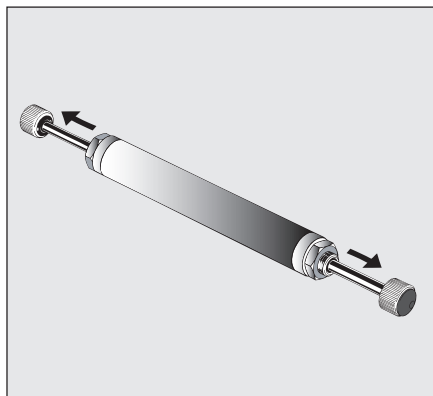

### ZDH 28 Bi-Directional Final Damper

The damper is fixed with the nuts and threads. Please make sure the impact direction is exactly parallel to the axis of the damper. We provide a fixing block as accessory

The damper is adjusted on both sides separately by turning the extended piston rod. The door should be slowed down gently, making sure it closes completely.

### Dimensions

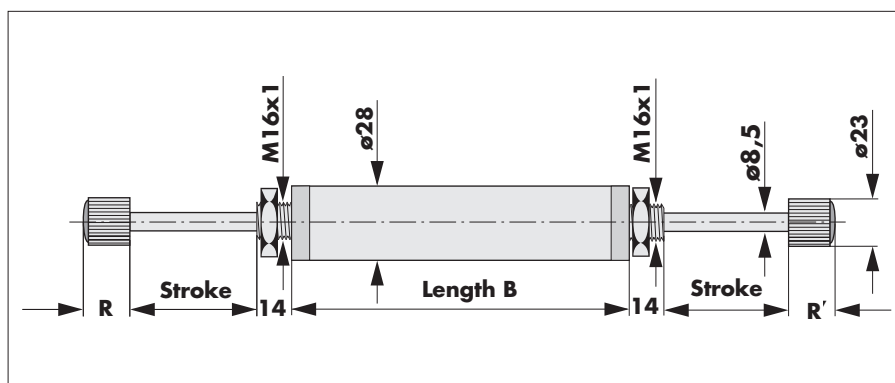

### Technical Data and Order Information

#### ZDH<sub>a</sub> 28 V 90 SP

Part no.	Stroke [mm]	Door weight max [kg]	Impact mass max. [N]	Returning force max [N]	Length B [mm]	Buffer R [mm]
210112	90	1000	3100	30	235	25

**Advice:** To help you select the appropriate damper, formulae and examples for calculating the required damping force can be found in the chapter Damping Engineering.

### Accessories

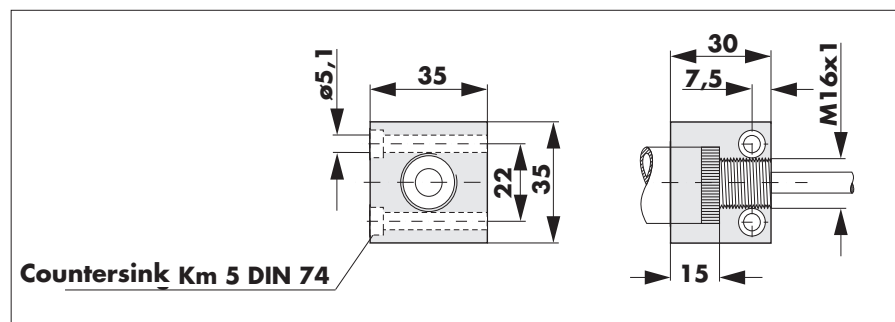
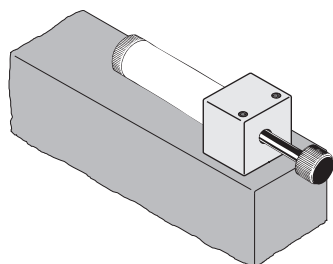

Countersink Km 5 DIN 74

Fixing block

Part no. 205199