

Oil Dampers with Fixings on Both Ends

Oil dampers with fixings on both ends are used when moving objects may not exceed a certain speed e.g. flaps, lids, lever arms. They are fixed at both ends and slow down the movement over the whole distance. The oil dampers control **pull** or **push forces** as well as pull **and** push forces.

Oil dampers with fixings on both ends are available in **2 designs**:

- as preset oil-damper **ÖD**
- as adjustable oil-damper **ÖDR**

With the preset oil dampers (**ÖD**) as economically priced alternative the required extending and retracting speed of the piston rod is preset during fabrication according to your requirements. The exact speed is subject to certain tolerances. It depends on the type of installation and on the tolerances of the boring in the piston.

The **adjustable** oil dampers (**ÖDR**) are the ideal solution when the forces cannot exactly be determined, as the damping force can be adjusted on site.

The fabrication of the oil dampers is generally to order. Therefore it is no problem to realise special, customised designs.



Technical Data

Diameter piston rod	ÖD: 6, 8, 10, 14 mm / ÖDR: 6, 10, 14, 25 mm
Diameter cylinder	ÖD: 19, 23, 28, 40 mm / ÖDR: 20, 28, 35, 69 mm
Strokes / Damping forces	20 mm - 1000 mm / up to 7500 N max.
Operating temperature	0 °C - 60 °C; on demand also other temperatures
Finish	cylinder zinc-plated or painted in RAL colours, piston rod hard chromed completely from AISI 304: ÖD, ÖDR 10-28 + 14-35; AISI 316 on demand
Damping fluid	hydraulic, biological oil
Maximum stroke frequency	6 strokes per minute

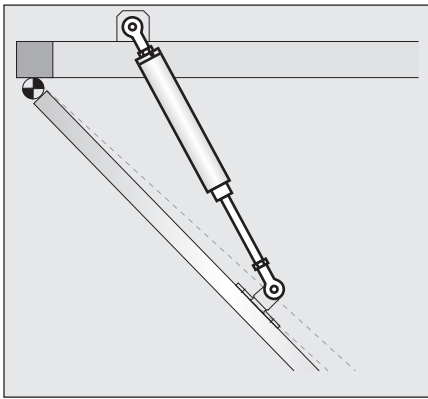

Preset Oil Dampers with Fixings on Both Ends, ÖD

Preset oil dampers are always produced to order. Stroke and therewith the length of the cylinder, end fittings, damping force and speed depend on the application it is designed for.

The speed realised when the oil damper has been fitted may vary from the adjusted speed. It depends on several parameters of the installation, for example the acting forces and the installation situation. The speed furthermore depends on the damping force. Therefore not all combinations of speed and damping force are possible. Please observe the tolerances given below.

End Fittings

On piston rod

On cylinder

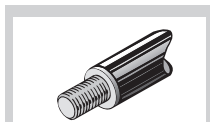

Threaded end **GZ**

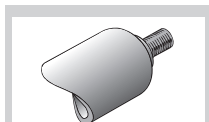

Threaded end **GZ**

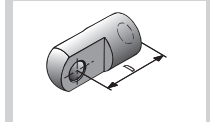

Eyelet **A**

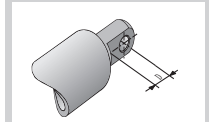

Eyelet **A**

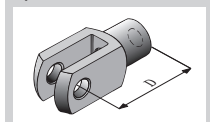

Fork **G**

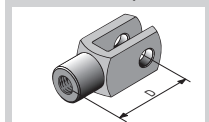

Fork **G**

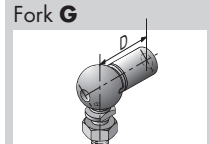

Ball and socket joint **WG**

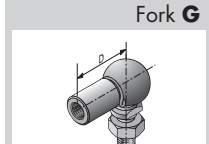

Ball and socket joint **WG**

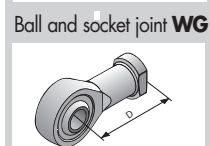

Rose bearing **GK**



Rose bearing **GK**

Exactly dimensioned drawings of the above end fittings with indication of size D can be found on page 03.031.00.

Determining your preset oil damper

With help of the following table you can easily find the correct oil damper if you already know the necessary stroke, force and end fittings. If you require other end fittings than the threaded end, simply add the measurement D of the chosen end fitting to the total length of the oil-damper.

If not all data are available or if you need technical advice, please contact our advisory service.

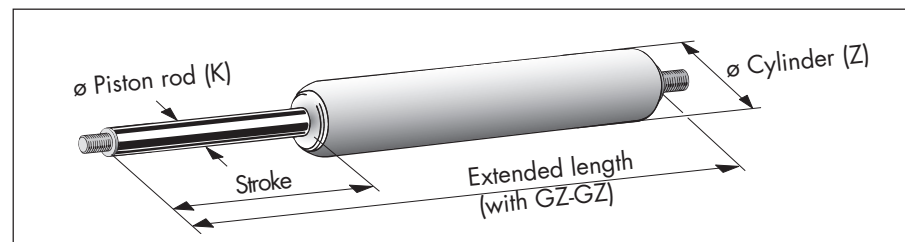

Required data	Diameters				Your ÖD
	6-19	8-23	10-28	14-40	
ø K / ø Z [mm]	6-19	8-23	10-28	14-40	<input type="text"/>
Max. stroke [mm]	250	400	500	500	<input type="text"/>
Type of damping	You can choose between: type of damping 1, 2, 3				<input type="text"/>
Damping fluid	oil	oil	oil	oil	<input type="text" value="oil"/>
Compressed length (Le)	extended length - stroke				<input type="text"/>
Extended length (La)	min. 2 x stroke + size F + size(s) D of end fittings				<input type="text"/>
size F	38	45	45	70	<input type="text"/>
Piston rod end fittings	GZ, A*, G, WG, GK (observe size D!)				<input type="text"/>
Cylinder end fittings	GZ, A*, G, WG, GK (observe size D!)				<input type="text"/>
Options	δ = protective tube (La + 5 mm)				<input type="text"/>
Required speed	meter per second ¹⁾ ≥ 0.02 m/s				<input type="text"/>
Max. damping force. [N]	400	700	1200	2500	<input type="text"/>

Types of damping

- 1 = damping on extending stroke (pull forces)
- 2 = damping on compressing stroke (push forces)
- 3 = damping on both extending and compressing stroke (push and pull forces)

¹⁾ **Speed tolerances** (due to production):

- | | | | |
|-------------------|-----------|-------------------|----------|
| Oil dampers 6-19 | +/- 25 %, | Oil dampers 8-23 | +/- 20 % |
| Oil dampers 10-28 | +/- 15 %, | Oil dampers 14-40 | +/- 15 % |

If you need a more precise or a lower speed, please contact our technical department.

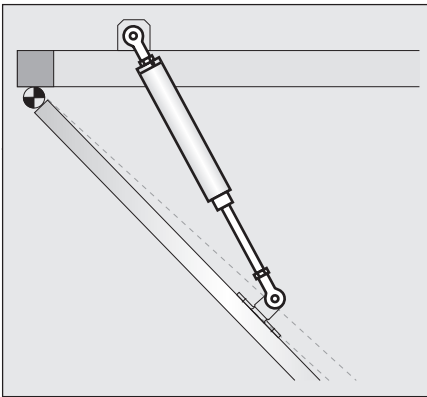

Adjustable Oil Dampers with Fixings on Both Ends, ÖDR

Adjustable oil dampers with fixings on both ends have - compared to the preadjusted oil dampers - a much more complicated design. However they are the ideal solution when the existing forces cannot be determined precisely. Damping force and speed are adjusted on site, once the damper has been installed.

The standard adjustable oil dampers are produced in 4 different ranges of diameters. Which diameter should be chosen depends amongst others on the required stroke and the damping force.

End Fittings

On piston rod

On cylinder

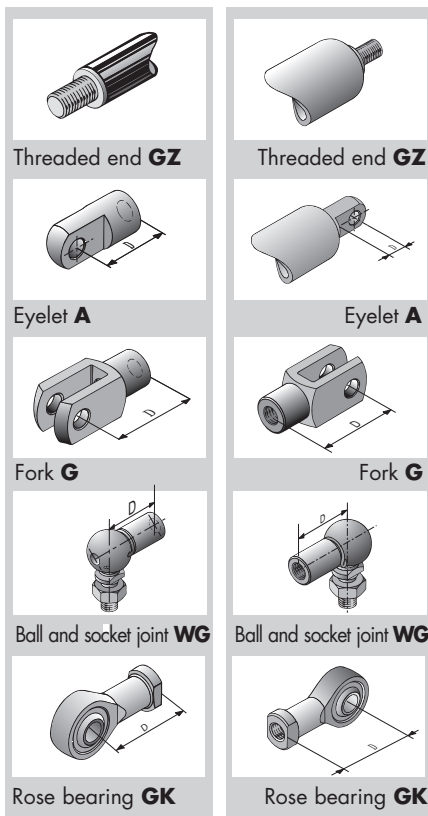

Exact dimensioned drawings of the above end fittings with indication of measurement D can be found on page 03.031.00.

Material

Standard: piston rod hard chromed
cylinder zinc-plated
Special types: 10-28 + 14-35 completely in stainless steel

Types of damping

- 1 = damping on extending stroke (pull forces)
- 2 = damping on compressing stroke (push forces)
- 3 = damping on both extending and compressing stroke (push and pull forces)

Determining your adjustable oil damper

With help of the following table you can easily find the correct oil damper if you already know the necessary stroke, force and end fittings. If you require other end fittings than the threaded end, simply add the measurement D of the chosen end fitting to the total length of the oil damper.

If not all data are available or if you need technical advice, please contact our advisory service.

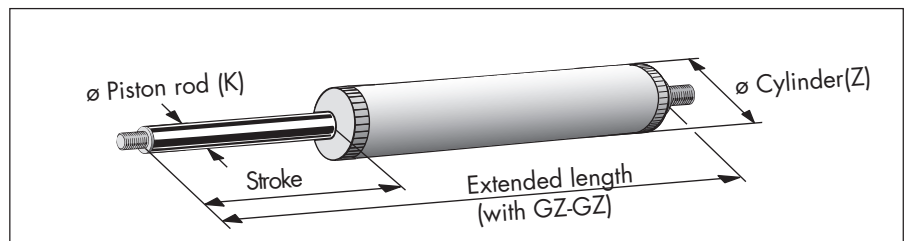

Required data	Diameters				Your ÖDR
	6-20	10-28	14-35	25-69	
ø K / ø Z [mm]	6-20	10-28	14-35	25-69	<input type="text"/>
Max. stroke [mm]	75	500	1000	1000	<input type="text"/>
Type of damping	You can choose between: type of damping 1, 2, 3				<input type="text"/>
Damping fluid	oil	oil	oil	oil	<input type="text" value="oil"/>
Compressed length (Le)	extended length - stroke				<input type="text"/>
Extended length (La)	min. 2 x stroke + size F + size(s) D of end fittings				<input type="text"/>
Measurement F	82	80	100	220	<input type="text"/>
Piston rod end fittings	GZ, A, G, WG, GK (observe size D!)				<input type="text"/>
Cylinder end fittings	GZ, A, G, WG, GK (observe size D!)				<input type="text"/>
Options	δ = protective tube (La + 20 mm!)				<input type="text"/>
Max. damping force [N]	220	1200	1200	7500	<input type="text"/>

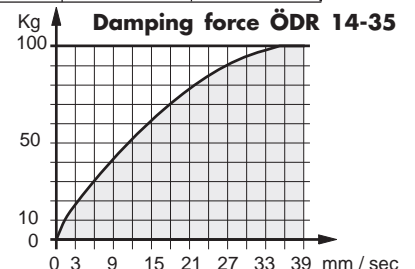
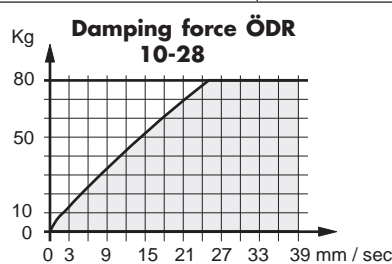

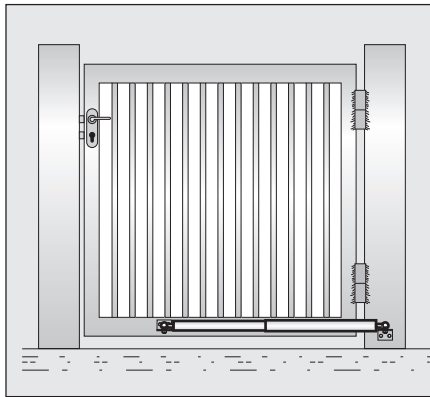

Adjustable Oil Dampers with Fixings, ÖDR 14-35 for Hinged Gates with Ascending Hinges

Hinged doors and gates with ascending hinges which are opened by hand close as soon as they are free. Depending on the size of the door/gate, high loads can build up when the door is closing. This represents a high injury risk for persons and it might damage the complete door installation. Besides, since 2005 the European norm EN 13241 demands better safety measures for such gates.

Dictator offers for this purpose adjustable oil dampers with fixings on both ends. They are fixed to the door and the wall/pillar and control the closing over the whole distance. The closing speed can be adjusted. These standard oil-dampers are available in 3 different sizes. By default they are provided with a protective tube.

Dimensions

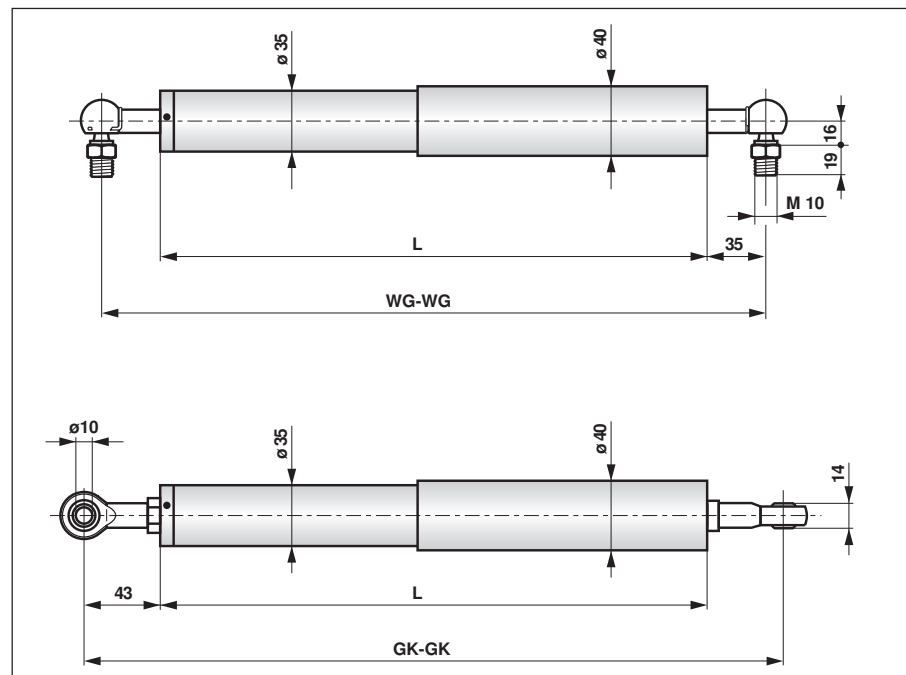

Technical Data and Order Information

Adjustable oil dampers ÖDR 14-35

Stroke [mm]	End fittings WG-WG*		End fittings GK-GK*	
	Extended length La [mm]	Part no.	Extended length La [mm]	Part no.
200	621	392500	637	392530
300	822	392510	838	392540
400	1005	392520	1021	392550

Max. tensile load 1000 N
Min. speed 0.05 m/s
Material / Finish Standard: piston rod hard chromed, cylinder and protective tube zinc-plated
 On demand, also completely in stainless steel

* The end fittings WG-WG or GK-GK do not interfere with the function of the damper. They simply depend on the type of fixing bracket being available.

Advisory Service

Gladly we will help you in choosing the most appropriate oil damper for your application. For this we need the following data:
 door dimensions, opening angle, incline.

End Fittings

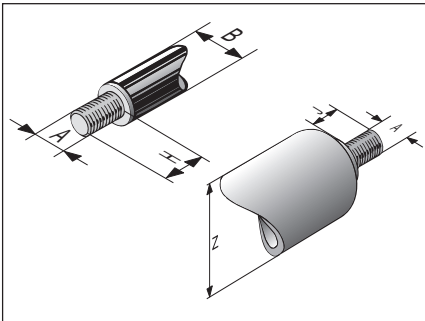

Threaded end on the piston rod (GZ)

	6-19 6-20	8-23	10-28	14-35	14-40	25-69
A	M5	M8	M8	M10	M10	M14x1,5
H	6,5	10	10	12	12	15
B	Ø6	Ø8	Ø10	Ø14	Ø14	Ø24

Threaded end on the cylinder (GZ)

	6-19	6-20	8-23	10-28	14-35	14-40	25-69
A	M5	M5	M8	M8	M10	M10	M14x1,5
J	8	8	12	12	12	12	15
Z	Ø19	Ø20	Ø23	Ø28	Ø35	Ø40	Ø69

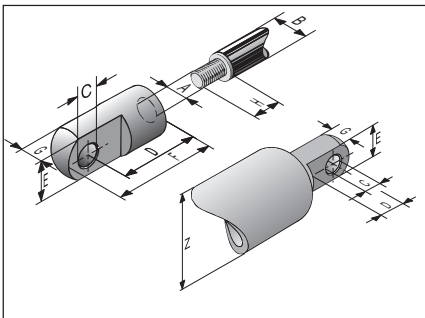

Eyelet with inside thread (A) - to be screwed onto

	6-19	6-20	8-23	10-28	14-35	14-40	25-69
A	M5	M5	M8	M8	M10	M10	M14x1,5
C	Ø6	Ø6	Ø8	Ø8	Ø8	Ø8	Ø14
D	16	16	22	22	30	30	45
E	10	10	14	14	18	18	25
F	21	21	32	32	40	40	58
G	6,5	6,5	10	10	10	10	14

Eyelet on cylinder end (A) - pressed into cylinder*

	6-19	8-23	10-28	14-40	* This eyelet is only available for the adjacent series. For all other series, please use the eyelet with inside thread both on the piston rod and the cylinder.	
C	Ø6	Ø8	Ø8	Ø14		
D	11	13	16	20		
E	10	14	18	25		
G	6	10	10	14		

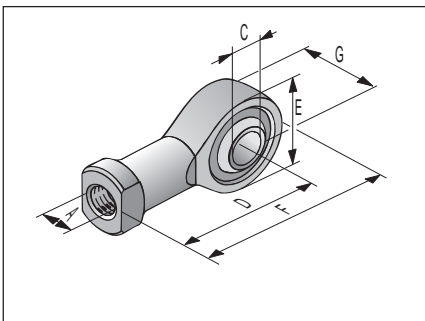

Rose bearing (GK) (for piston rod and cylinder)

	6-19/6-20	8-23	10-28	14-35/14-40	25-69
Part no.	205800	205801	205801	205802	205805
A	M5	M8	M8	M10	M24
C	5	8	8	10	25
D	27	36	36	43	94
E	18	24	24	28	61
F	36	48	48	57	125
G	8	8	8	14	31

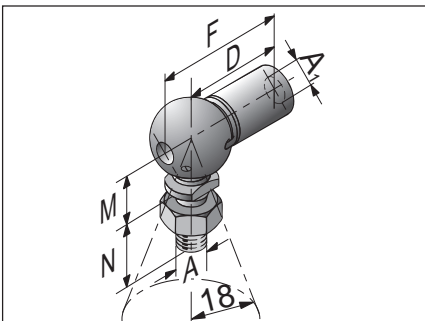

Ball and socket joint (WG) DIN 71802 (for piston rod and cylinder)

	6-19	6-20	8-23	10-28	14-35	14-40	25-69
A ₁ /A	M5	M5	M8	M8	M10	M10	M14x1,5
D	18	22	30	30	35	35	45
F	28	28	39	39	46	46	60
M	9	9	13	13	16	16	20
N	10	10	16	19	19	19	28

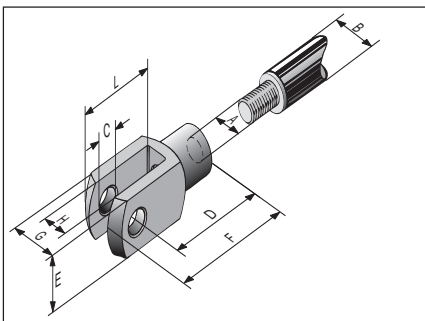

Fork (G) DIN 71752 (for piston rod and cylinder)

	6-19	6-20	8-23	10-28	14-35	14-40	25-69
A	M5	M5	M8	M8	M10	M10	M14x1,5
B	Ø6	Ø6	Ø8	Ø10	Ø14	Ø14	Ø24
C	Ø5	Ø5	Ø8	Ø8	Ø10	Ø10	Ø14
D	20	20	32	32	40	40	56
E	10	10	16	16	20	20	27
F	26	26	41	41	52	52	72
G	10	10	16	16	20	20	27
H	5	5	8	8	10	10	14
L	16	16	25	25	32	32	44

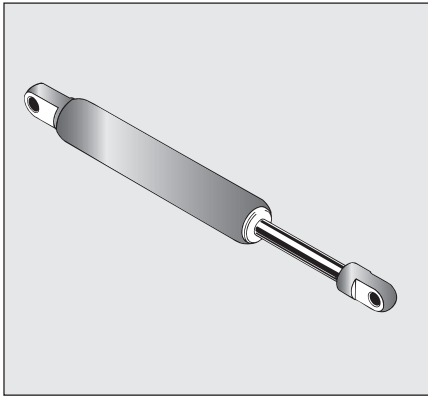

Installation, Fixing Brackets

Adjusting the Damping of the ÖDR

The adjusting of the damping force works the same way as with the final dampers with stepped adjustment (see page 03.005.00).

Standard stepped adjustment: The piston rod is pulled out completely (Attention: For this purpose you should never use nippers as this would damage the surface of the piston rod and following the seal). Then you increase or decrease the damping force by turning the piston rod.

Some oil dampers are produced with the adjustment when the piston rod is completely pushed in. Please observe the label on the cylinder!

Adjusting with the completely pulled out piston rod

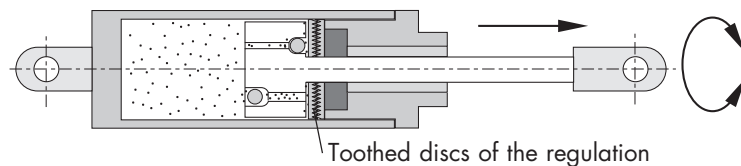

Adjusting with the completely pushed in piston rod

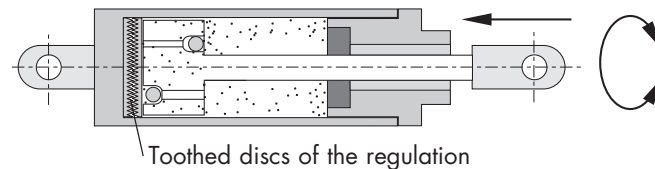

Installation Instruction

Oil dampers start damping only after a few millimeters of travel.

Oil dampers should not be used as a final stopping device. It is recommended to provide a separate mechanical final stop.

Fixing Accessories

For the mounting of the oil dampers various fixing brackets are available. The type of bracket to be chosen depends on the end fittings of the oil damper and the type of mounting (lateral or frontal). A large variety can be found in the chapter gas springs of this catalogue.